



Woltman Silver Turbo - Water Meter

Model WST

The new Woltman Silver Turbo – WST is the latest state of the art meter developed by ARAD’s R&D department.

Advanced methods and technologies were implemented in order to present a product much superior to those found in the market today.

Features:

In addition to the features offered by Arad’s traditional Woltman Turbine meter, the Woltman Silver Turbo (WST) offers the following:

- Accuracy – The WST’s accuracy curve is the widest known in the market: The minimum flow rate is 35%-58% below the ISO standard for such meters and the maximum flow rate is 150%-233% above it. The combination of these unique features allows the use of the WST in broader applications and in extreme situations.
- Ratios – The ratio between the extreme flow rates (Q min and Q max) is:
 - 1:330 in the 2” WST - 1:169 in the 6” WST
 - 1:400 in the 3” WST - 1:146 in the 8” WST
 - 1:375 in the 4” WST
- Resistance – Bearings and materials used in the WST have been proved to ensure durability far beyond the ISO Standard requirement. This feature ensures that the meter can function in extreme conditions where other meters fail to maintain a sufficient level of accuracy.
- Magnetic Coupling – The WST, like its predecessor, the Woltman Turbo meter - has a unique measuring unit, in which only one moving element, the impeller, is in contact with the water. The other moving components, including the worm & trans-

mission gear, are kept sealed inside a dry compartment and have no contact with any of the abrasive elements present in the water.

- WST has repelling magnets installed in the impeller and the transmitting gear, instead of the attracting magnets installed in the WT
- Compatibility – The WST is also available with EV, EF, Dialog 2G, Dialog 3G, etc. The WST’s measuring unit can be installed in any of the existing Arad WT models.

Applications

Water supply networks, agricultural applications and industrial use.

Available Sizes

2” - 8” (50mm - 200mm)

Standards

ISO 4064, AWWA, EEC

Technical Specifications

Maximum Working Pressure	Standard - 16 bar Upon request – 25 bar
Maximum Liquid Temperature	60°C
Body	Cast iron, polyester coated. Optional - bronze (AWWA std.).
Connection	Flanges according to ISO, BS 10, AWWA or others.



WST type dial



- ▶ Woltman meters
 - └ WST
 - Irrigation & Agriculture
 - Compound meters
 - Fire Service meters
 - Electromagnetic & Ultrasonic

Performance data:

Model WST		Qmax Maximum flowrate (m ³ /h)	Qn ISO 4064 (m ³ /h)	Qn Nominal Flowrate (m ³ /h)	Qt Transitional Flowrate (m ³ /h)	Qmin Minimum Flowrate (m ³ /h)	Starting Flow (m ³ /h)	Minimum register capacity (m ³)	Minimum register capacity (liter)	Accuracy between Qmax & Qt	Accuracy between Qt & Qmin
Nominal Size											
mm	inch										
50	2	100	15	50	0.7	0.3	0.15	106	1	±2%	±5%
80	3	200	40	120	0.8	0.5	0.25	106	1		
100	4	300	60	230	1.8	0.8	0.3	107	1/10		
150	6	410	150	260	3.5	2.5	0.8	107	10		
200	8	730	250	450	15	5	2	108	100		

Dimensions

Model		WST				
Nominal size	(mm)	50	80	100	150	200
	(inch)	2	3	4	6	8
L – Length (mm)		200	230	250	300	350
B – Width (mm)		165	200	200	283	340
H – Height (mm)		214	234	250	310	338
h – Height (mm)		70	90	106	130	158
Weight (kg)		12	15.5	19	35	47

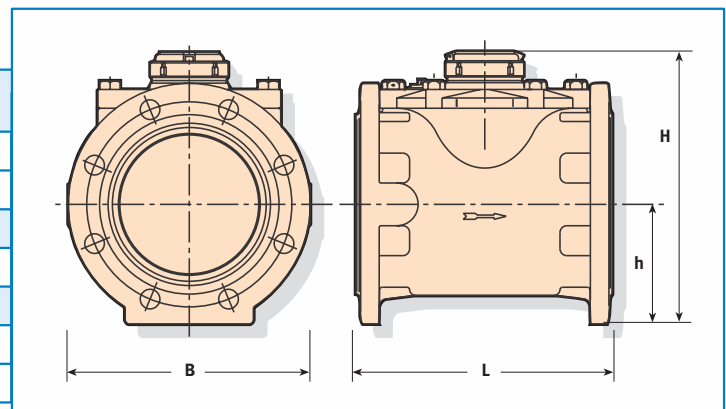

Head Loss Curve

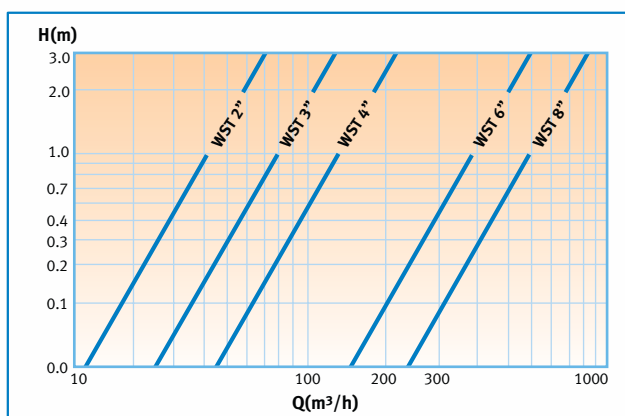

Installation Requirements

- The water meter may be installed in any position. For non-horizontal positions the flow shall be upwards.
- The meter shall be full of water while operating.
- Prior to installation of a meter, the pipeline shall be thoroughly flushed.
- Straight pipe section of the same diameter D as the meter, having length of 5D and 2D shall be installed upstream and downstream of the meter respectively.

